



Custom solutions for

- | Food processing
- | Laboratories
- | Agriculture
- | Veterinary medicine
- | Pharmaceutical industry

1300 798 380

www.thermalmark.com.au



We are always glad to help!

1300 798 380

www.thermalmark.com.au

TMR *We Keep it Cool*
Thermal Mark
Transport Refrigeration



Contact

Internet:

www.dometic-waeco.com

Always a good link: the Dometic WAECO website. That's where you will find the complete Dometic and WAECO range. Plus interesting news about our company, information about the latest special offers, and online order forms for more special catalogues.

1300 798 380

www.thermalmark.com.au



TMR *We Keep it Cool*
Thermal Mark
Transport Refrigeration



One-degree accuracy

Temperature controlled transport for genuine professionals

Taking highly perishable goods safely from one place to another – no problem with mobile refrigeration by Dometic WAECO. Our portable coolers have stood and passed the test of practice millions of times. To meet your demanding logistics needs they are fitted with special, high-performance electronics. Whatever it is you are transporting – lab samples, doses of semen or perishable food – WAECO and Dometic products provide one-degree accuracy for your freight!

1300 798 380
www.thermalmark.com.au

TMR *We Keep it Cool*
Thermal Mark
Transport Refrigeration

Contents



6 – 9

Intro

Temperature controlled transport with Dometic WAECO technology

Special information on HACCP

Product overview

10 – 15

Mobile refrigeration

Coolers

- | Thermoelectrics
- | Extra modules for thermoelectric coolers

16 – 30

Mobile refrigeration

Kühlboxen

- | Compressor technology
- | Extra modules for compressor coolers

Customised built-in solutions

- | Compressor technology

31 – 35

Mobile refrigeration

Custom solutions for catering and refrigerated transport

- | Dometic refrigerator and warmer cabinet
- | Dometic catering refrigerators
- | WAECO compressor cooling container

36 – 37

Mobile refrigeration

Fully integrated cooling kits for refrigerated and deep-freeze vehicles

1300 798 380

www.thermalmark.com.au



The right temperature –

Key to your success

“Cool” is a relative term. Depending on the outside temperature and transported items, it may cover temperatures between -18°C and $+40^{\circ}\text{C}$. **Correct storage at a constant temperature is the key to success** for each temperature-sensitive product. You know the right temperature for your product. WAECO sets up the cooler to match. **The temperature is preset at our factory** and kept constant at a maximum deviation of $\pm 2^{\circ}\text{C}$ – or even less if required. Of course we can also preset **two different fixed values**, or leave the temperature adjustment in your hands. We can also install a **heater with three-point controller** for additional safety ...



Food samples: safe storage and accurate temperature management in the thermoelectric incubator box with factory preset fixed temperature



Dialysis products: best transported in a special thermoelectric box with factory preset fixed temperature (interior temperature limited at 37°C).



Doses of semen: safe transport without temperature deviations in a special thermoelectric box. Data logger for continuous temperature recording.

HACCP – Dometic WAECO fills the gaps in the cold chain

HACCP stands for Hazard Analysis Critical Control Points, an internationally binding quality management system for food products. The principle behind it is that all critical points in the delivery chain “from the stable to the table” are closely examined on the spot. For all critical points, limiting values are defined and then continuously checked and documented.

Critical risks are always involved when perishable food is exposed to high temperatures, e.g. while shopping or delivering to a customer. Investing in a refrigerated truck is not always financially viable. Why not save money and gain flexibility with mobile refrigeration by Dometic WAECO?

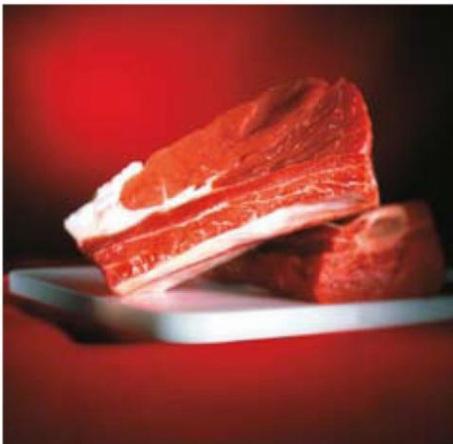

1300 798 380

www.thermalmark.com.au



Thermal Mark
Transport Refrigeration

A profitable business

HACCP not only gives you satisfied customers, it boosts your profits. Success is in the system: implementing an HACCP concept means checking and revising all in-house processes. Even though potential health risks for consumers are the decisive criteria, the inspection will also reveal other shortcomings. The outcome: streamlined processes, minimised losses, optimum use of resources.

HACCP with mobile refrigeration by Dometic WAECO

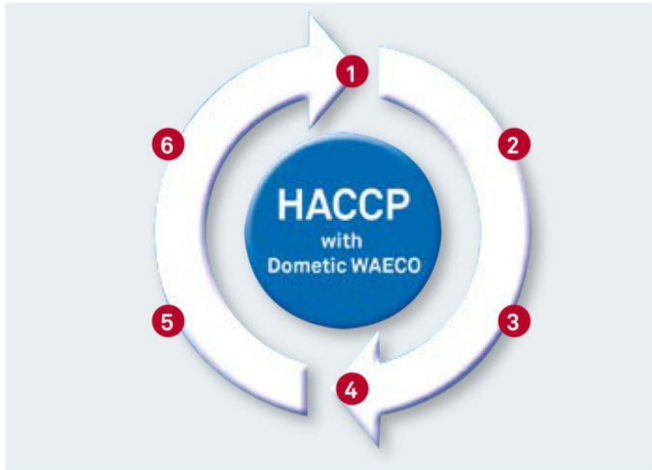

1. **Hazard Analysis:** Analyse the hazards to consumers' health.
2. **Critical Control Points:** Trace the critical points in your cool chain.
3. **Define the critical limiting values:** What is the right temperature for your product(s)?
4. **Safety precaution:** Integrate coolers into your cool chain.
5. **Fine tuning:** Which cooler for which product? Do you need a special version?
6. **Documentation:** Not compulsory, but recommended – and no problem with Dometic WAECO!

Good reasons for HACCP

| More quality: safe and healthy food

| Satisfied customers

| More profit: better process management

| Prevention of legal risks and damage to your reputation

Mobile professionals for a continuous cold chain

On pages 31 – 35 we present to you five **transport solutions for professional kitchen use**, all designed by Dometic Luxembourg, specialist in professional cooling solutions for medical and catering applications. **The compressor-powered cooling container WAECO CoolFreeze 850VAN (pages 34 – 35) recommends itself as a low-cost alternative to a converted van.**

| Dometic refrigerator and warmer cabinet **Page 31**

| Dometic catering refrigerators **Pages 32 – 33**

| WAECO compressor cooling container **Pages 34 – 35**



1300 798 380

www.thermalmark.com.au



Thermal Mark
Transport Refrigeration

Thermoelectrics

Precision from +1°C to +65°C

Thermoelectric custom coolers for temperature controlled transport are based on the tried and tested concept of WAECO TropiCool standard coolers (p. 10 – 13). Just add the modules of your choice (p. 14 – 15) to create your own customised solution quickly and cost-effectively.



WAECO TropiCool TC-35FL

- | Ideal for temperatures from +1°C to +15°C and +50°C to +65°C
Cooling capacity depends on the outside temperature
- | Accurate temperature control $\pm 2^\circ\text{C}$
- | Lightweight and easy to transport
- | In four sizes (7, 14, 21, 35 litres)
- | Flexible energy supply:
12/24/230 volts as standard (TC-07 12/230 volts)
- | Customised with extra modules (p. 14 – 15)

Compressor technology

Cool power from -18°C to $+10^\circ\text{C}$

Compressor-powered custom coolers for temperature controlled transport are based on the tried and tested concept of WAECO CoolFreeze standard coolers (p. 16 – 25). Just add the modules of your choice (p. 26 – 27) to create your own customised solution quickly and cost-effectively.



WAECO CoolFreeze CF-80

- | Powerful cooling from -18°C to $+10^\circ\text{C}$
- | Heating up to $+40^\circ\text{C}$ with extra heater
- | Accurate temperature control $\pm 2^\circ\text{C}$
- | Also for larger cooling capacities (10.5 to 106 litres)
- | Flexible energy supply: 12/24/100 – 240 volts as standard (models from CF-35 upwards)
- | Customised with extra modules (p. 26 – 27)

Extra modules



Factory preset fixed temperature with digital readout



Performance booster: interior fan



Temperature check at the wheel: data from the radio thermometer



Removable data logger with USB interface



Real-time documentation: temperature logger + mini-printer + software

1300 798 380
www.thermalmark.com.au

Eutectics

High-tech made to measure

Eutectic coolers (p. 26) are ideal for temperature controlled transport of sensitive high-end products.

35 h cooling without power
CF-50, CF-60,
CF-80 and CF-110
+ eutectics



- | Factory preset fixed temperature
- | Pre-cooling on the 230-volt mains
- | Up to 35 hours cooling without energy supply at ambient temperatures up to +30°C
- | Optionally with GSM module for remote monitoring of inside and outside temperature
- | In four sizes: CF-50, CF-60, CF-80, CF-110 *

* Net capacity is reduced by about 1/3 due to the retrofitted eutectic module

Customised built-in solutions

Preset fixed point temperature

Ideal for ambulances and rescue vehicles: practical built-in appliances for safe transport of temperature sensitive products at the prescribed temperature (p. 28 – 29). With compressor cooling or integrated heater. Interior temperature limited at a level to suit the product stored.



WAECO CoolMatic MH-07

WAECO CoolMatic MR-07



WAECO CoolFreeze MC-045

- | | |
|--|---|
| Built-in cabinets with compressor cooling or heating | Built-in cooler with compressor cooling |
| Fixed point temperature preset at +4°C or +40°C | Fixed point temperature preset at +5°C |
| Gross capacity approx. 7 litres | Gross capacity approx. 5 litres |
| Door and installation frame in stainless steel | Permanent (theft-proof) installation |

Extra modules

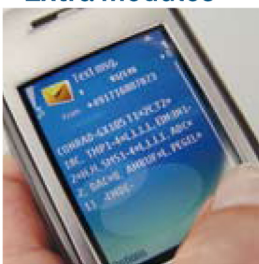

A text will do: GSM module for remote data retrieval



35 h cooling without power: compressor cooler + eutectic module



Safety all the way: Fixed point temperature preset at +4°C or +40°C



Ideal in confined spaces: detachable cooling unit with 1.5 m supply cable (MR-07)

1300 798 380

www.thermalmark.com.au

WAECO TropiCool TC-35FL
35 litres capacity

12/24 volts DC
and
230 volts AC
as standard!



WAECO TropiCool TC-14FL
14 litres capacity



WAECO TropiCool TC-21FL
21 litres capacity



WAECO TropiCool TC-07
7 litres capacity

Thermoelectrics

12/24 volts DC and 230 volts AC as standard!

Lightweight, low-priced, versatile – these are the hallmarks of thermoelectric refrigeration. The **wear-free technology** is great for low-capacity heating or cooling of **small to medium-sized spaces**. It is based on the thermoelectric principle – which states that **heat or cold** is generated when the connection between different metals is linked to a direct current power source (Peltier

effect). The WAECO **TropiCool standard range** (p. 12 – 13) gives you a choice of four sizes ranging from a compact 7-litre cooler to a spacious 35-litre appliance. The three larger models (TC-14FL, TC-21FL and TC-35FL) are **fitted as standard with TC special electronics** and a **12/24/230-volt connection**.

To suit temperature controlled transport needs Dometic WAECO standard boxes can be fitted with customised extra modules. Read more on this on pages 14 – 15.



Aerospace technology for cooling and heating; the thermoelectric Peltier element works accurately, wear-free and without any refrigerant.

1300 798 380
www.thermalmark.com.au

TMR *We Keep it Cool*
Thermal Mark
Transport Refrigeration

Well-engineered technology for enhanced user comfort

Perfect down to the last detail – product benefits of the TropiCool series



1 TC special electronics with soft-touch operating panel

WAECO TropiCool coolers* provide refrigeration up to 30°C below the ambient temperature and heating up to +65°C. Using the soft-touch operating panel, you can set the desired temperature in seven stages each: from +1°C to +15°C in the cooling mode, or from +50°C to +65°C in the heating mode. The memory function saves the last set parameters.

- › Cooling up to 30°C below ambient temperature
- › Heating up to +65°C
- › 7-stage temperature regulation for cooling and heating
- › LED temperature display
- › Memory function saves the last settings
- › Membrane keypad protects the electronics from dust and moisture

* All models except TC-07

Note:

For temperature controlled transport, TropiCool coolers can be fitted with a highly sensitive electronic system (p. 14 – 15) that allows temperature control in tight tolerances. The soft-touch operating panel is replaced by a digital display.

2 Highly effective insulation

Outstanding energy efficiency

3 Dynamic interior ventilation

Significantly improved cooling performance

4 Wear-free fans

Long service life

5 Intelligent power-save circuit

Electronics switch automatically to power-save mode once the desired interior temperature has been reached (for TC-14FL, TC-21FL and TC-35FL)

6 12/24/230 volts as standard

With priority circuit for 230 volts

7 Heat exchanger and high-performance Peltier element

Cooling performance up to 30°C below ambient temperature!

8 Magnetic switch

Switches the interior fan off when you open the cooler

9 Universal fixing kit

for TC-14FL, TC-21FL and TC-35FL (p. 12)



1300 798 380

www.thermalmark.com.au

TMR *We Keep it Cool*
Thermal Mark
 Transport Refrigeration

WAECO TropiCool TC-07

Thermoelectric cooler

4.01

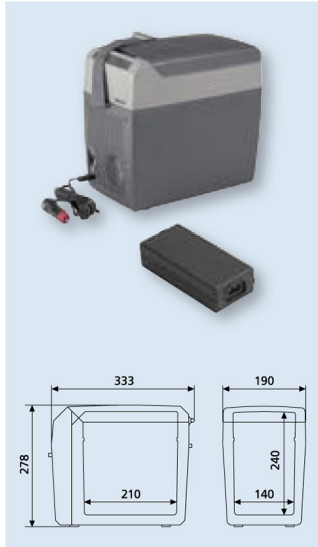

Gross capacity	approx. 7 litres
Voltage	12/230 volts DC/AC
Power consumption	approx. 36 watts
Temperature range	Cooling: approx. +5°C (up to 25°C below ambient temperature); Heating: approx. +65°C
Insulation	Polyurethane full-foam insulation
System	Wear-free thermoelectrics (Peltier system), cold/heat transmission to the interior through coated aluminium container, heat dissipation to the outside by brushless, wear-free fan
Colour	Dark grey/pale grey
Weight	approx. 2.8 kg
Quality features	Temperature regulation for cooling and heating with fixed point thermostats, ready for connection to 230 volts
Scope of delivery	Shoulder strap, 12-volt connection cable and 230-volt mains adapter included
Test marks	CE, TÜV/GS, e-approved to 2006/28/EC (Automotive EMC Directive)
Product	Ref. No.
TropiCool TC-07	TC-07UG-12/230

Up to 25°C below ambient temperature

Up to +65°C in the heating mode

12/230 volts

WAECO TropiCool TC-14FL

Thermoelectric cooler with TC special electronics

4.01

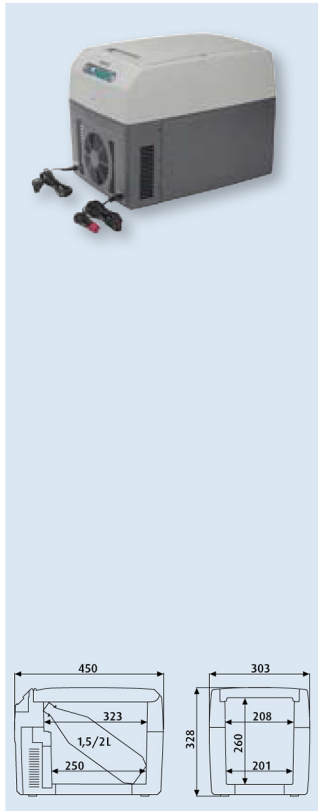

Gross capacity	approx. 14 litres
Voltage	12/24 volts DC and 230 volts AC
Power consumption	approx. 55 watts at 12 V DC approx. 60 watts at 24 V DC approx. 80 watts at 230 V AC
Average running time	30% at +20°C ambient temperature
Temperature range	Cooling: +1°C to +15°C (up to 30°C below ambient temperature); Heating: +50°C to +65°C
Insulation	Polyurethane full-foam insulation
System	Wear-free thermoelectrics (Peltier system), cold transmission to the interior by dynamically ventilated aluminium heat exchanger, heat dissipation to the outside by high-performance heat exchanger and brushless, wear-free fan
Material	Sturdy injection moulded parts
Colour	Dark grey/pale grey
Weight	approx. 5.0 kg
Quality features	TC special electronics: 7-stage electronic thermostat with LED indicators, memory function, ON/OFF and cold/warm option activated with soft-touch operating panel, intelligent power-save circuit. Integrated mains supply unit with priority circuit, outstanding cooling performance, magnetic switch to deactivate the interior fan when the box is opened, detachable lid with magnetic closure, sturdy, fold-away handle
Test marks	CE, TÜV/GS, e-approved to 2006/28/EC (Automotive EMC Directive)
Product	Ref. No.
TropiCool TC-14FL	TC-14FL-AC
Optional extra	
Universal fixing kit	UFK-T

Up to 30°C below ambient temperature

Up to +65°C in the heating mode

12/24/230 volts

TC special electronics

Universal fixing kit

For TropiCool TC-14FL, TC-21FL, TC-35FL: fastening of TropiCool coolers in vehicles.

4.01

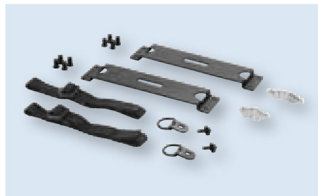

Material	Powder-coated metal
Colour	Black
Scope of delivery	Two base plates, two adjustable straps, set of screws
Product	Ref. No.
Universal fixing kit	UFK-T



WAECO TropiCool TC-21FL

Thermoelectric cooler with TC special electronics

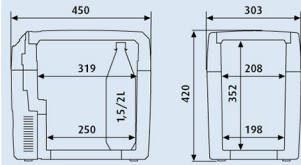

Gross capacity	approx. 21 litres
Voltage	12/24 volts DC and 230 volts AC
Power consumption	approx. 55 watts at 12 V DC approx. 60 watts at 24 V DC approx. 80 watts at 230 V AC
Average running time	32% at +20°C ambient temperature
Temperature range	Cooling: +1°C to +15°C (up to 30°C below ambient temperature); Heating: +50°C to +65°C
Insulation	Polyurethane full-foam insulation
System	As for TC-14FL
Material	Sturdy, injection-moulded parts
Colour	Dark grey/pale grey
Weight	approx. 6.0 kg
Quality features	TC special electronics: 7-stage electronic thermostat with LED indicators, memory function, ON/OFF and cold/warm option activated with soft-touch operating panel, intelligent power-save circuit. Integrated mains supply unit with priority circuit, outstanding cooling performance, magnetic switch to deactivate the interior fan when the box is opened, detachable lid with magnetic closure, sturdy, fold-away handle, vertical space for 2-litre bottles, adjustable grid divider

Test marks	CE, TÜV/GS, e-approved to 2006/28/EC (Automotive EMC Directive)
-------------------	---

Product	Ref. No.
---------	----------

TropiCool TC-21FL	TC-21FL-AC
-------------------	------------

Optional extra	
----------------	--

Universal fixing kit	UFK-T
----------------------	-------

WAECO TropiCool TC-35FL

Thermoelektrische Kühlbox mit TC-Spezialelektronik

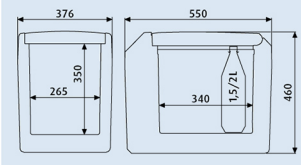

Gross capacity	approx. 35 litres
Voltage	12/24 volts DC and 230 volts AC
Power consumption	approx. 55 watts at 12 V DC approx. 60 watts at 24 V DC approx. 80 watts at 230 V AC
Average running time	35% at +20°C ambient temperature
Temperature range	Cooling: +1°C to +15°C (up to 30°C below ambient temperature); Heating: +50°C to +65°C
Insulation	Polyurethane full-foam insulation
System	As for TC-14FL
Material	Sturdy, injection moulded parts
Colour	Dark grey/pale grey
Weight	approx. 10.0 kg
Quality features	TC special electronics: 7-stage electronic thermostat with LED indicators, memory function, ON/OFF and cold/warm option activated with soft-touch operating panel, intelligent power-save circuit. Integrated mains supply unit with priority circuit, outstanding cooling performance, magnetic switch to deactivate the interior fan when the box is opened, detachable lid with snap lock closure, handy carrying grips, vertical space for 2-litre bottles, adjustable grid divider

Test marks	CE, TÜV/GS, e-approved to 2006/28/EC (Automotive EMC Directive)
-------------------	---

Product	Ref. No.
---------	----------

TropiCool TC-35FL	TC-35FL-AC
-------------------	------------

Optional extra	
----------------	--

Universal fixing kit	UFK-T
----------------------	-------

Up to 30°C below ambient temperature

Up to +65°C in the heating mode

12/24/230 volts

TC special electronics

4.01

Up to 30°C below ambient temperature

Up to +65°C in the heating mode

12/24/230 volts

TC special electronics

1300 798 380

www.thermalmark.com.au



WAECO TropiCool Accessories

High-tech à la carte –

Your tailor-made box, step by step

Well-proven thermoelectrics plus special modules of your choice – it just takes a few easy steps to create your own customised box. Start by choosing the right-sized appliance from our standard programme (7, 14, 21 or 35 litres, p. 12 – 13), then combine it with the extra modules you need. The table below shows you which modules are available for which cooler.



Thermoelectrics
+ extra modules
= custom-made
cooling

Easy documentation – from the logger to the laptop or thermal printer



For the sake of continuous, tamper-proof temperature recording the data logger is firmly integrated in the cooler. Data can be transferred to a laptop computer via a data cable with infrared interface – or printed out directly using the attachable printer.

Extra modules available for thermoelectric coolers

Thermo-electric coolers	DTTC-01 Digital temperature readout	DTTC-02 One factory preset fixed temperature	DTTC-03 Variable temperature	DTTC-04 Interior fan	DTTC-05 Heater with three-point controller	DTTC-06 Digital radio thermometer	DTTC-07 Data logger with software and USB port	DTTC-08 Thermal printer	DTTC-09 Two factory preset fixed temperatures	DTTC-12 Data logger as single unit without software	DT-13 3-pin plug-in system
TC-07 approx. 7 litres up to 25°C below ambient temperature	●	●		●		●	●	●	●	●	●
TC-14FL approx. 14 litres up to 30°C below ambient temperature	●	●		●	●	●	●	●	●	●	●
TC-21FL approx. 21 litres up to 30°C below ambient temperature	●	●	●	●	●	●	●	●	●	●	●
TC-35FL approx. 35 litres up to 30°C below ambient temperature	●	●	●	●	●	●	●	●	●	●	●

1300 798 380

www.thermalmark.com.au

TMR
We Keep it Cool
Thermal Mark
Transport Refrigeration

Extra modules for thermoelectric coolers



DTTC-01
Digital readout of the current temperature inside the box. Replaces the soft-touch operating panel of the TC standard boxes.

Product	Ref. No.
Digital temperature readout	DTTC-01



DTTC-06
Digital radio thermometer transmits current temperature to the dashboard-mounted display unit (display unit included in the delivery kit).

Product	Ref. No.
Digital radio thermometer	DTTC-06

DTTC-02
One fixed temperature in a range from +10°C to +40°C preset in the factory. Tolerance: ± 2°C (independent of outside temperature; closer upon request). Test log supplied as standard.

Product	Ref. No.
One factory preset fixed temperature	DTTC-02



DTTC-07
Data logger with software and USB connection for continuous recording of the temperature.

Product	Ref. No.
Data logger with software and USB	DTTC-07



DTTC-03
Temperature variable in a range from +10°C to +40°C with temperature controller. Control electronics reliably compensate for deviations from preset value. Tolerance: ± 2°C (closer upon request).

Product	Ref. No.
Variable temperature	DTTC-03



DTTC-08
 Attachable **mini-printer** for real-time, on-site documentation.

Product	Ref. No.
Thermodrucker	DTTC-08



DTTC-04
High-performance fan for fast cooling or heating and uniform air circulation inside the box.

Product	Ref. No.
Interior fan	DTTC-04

DTTC-09
Two preset fixed temperatures in a range from +10°C to +40°C. Easy change from one value to another with rocker switch. Tolerance: ± 2°C (independent of outside temperature; closer upon request). Test log supplied as standard.

Product	Ref. No.
Two factory preset fixed temperatures	DTTC-09

DTTC-05
Extra heater for fast heat-up (reduces wear on the Peltier element). Safer operation at extreme outside temperatures. With automatic three-point-controller (heat/OFF/cool).

Product	Ref. No.
Heater with three-point-controller	DTTC-05



DTTC-12
Data logger as single unit, without software.

Product	Ref. No.
Data logger as single unit without software	DTTC-12



DT-13
3-pin plug-in system for built-in power supply. Max. power input 25 A at 6 – 24 volts. Flat terminals (4 x 6.3 mm, 1 x 4.8 mm).

Product	Ref. No.
3-pin plug-in system	2225400001

Special requests welcome!

With the extra modules mentioned above the potential of our thermoelectric custom coolers is by no means exhausted. More features can be integrated upon request. Challenge our creativity – join us to design a customised solution to suit your needs!

CF special electronics
with soft start and turbo cooler



WAECO CoolFreeze CF-35
31 litres capacity



WAECO CoolFreeze CF-40
37 litres capacity



WAECO CoolFreeze CF-50
49 litres capacity



NEW! WAECO CoolFreeze CF-60
49 litres capacity

Cool power. Compressor technology

12/24 volts DC and 100 – 240 volts AC as standard!

Excellent cooling performance from -18°C to $+10^{\circ}\text{C}$, low energy consumption, ultra-quiet running – features you can depend on with each compressor appliance from Dometic WAECO.

The CoolFreeze standard programme (pages 18 – 25) gives you a choice of **nine different-sized models** – from a compact 10.5-litre box right through to a spacious 106-litre cooling container. All larger versions (from CF-35 upwards) are **fitted as standard with CF special electronics and are ready for connection to 12/24 volts DC and 100 – 240 volts AC.**

To suit temperature controlled transport needs Dometic WAECO standard boxes can be fitted with customised extra modules. Read more on this on pages 26 – 27.

One cooler – two transport options:

The compact CoolFreeze CDF-18 with the practical carrying handle also comes in a wheeled version, CoolFreeze CDF-18T. The trolley is included in the delivery kit.

Handle
or
trolley

WAECO CoolFreeze CDF-18T
18 litres capacity



1300 798 380

www.thermalmark.com.au

Well-engineered technology for enhanced cooling efficiency

Perfect down to the last detail – product benefits of the CoolFreeze CF series



1 CF special electronics with digital temperature display, soft start and turbo cooler

Turbo power with economy. The CF special electronics system gives the compressor a soft and power-saving start at 2500 rpm. If the preset temperature is not reached within a short period of time or a temperature below -12°C has been set, the turbo cooler switches on automatically to boost the compressor speed. As soon as a preset temperature up to -12°C has been reached, the system switches back to economy mode (except if a temperature below -12°C has been set). **The outcome: fast yet economical cooling from $+10^{\circ}\text{C}$ to -18°C .**

- › Intelligent, automatic turbo cooler
- › 3-stage battery protection to be set on the digital display
- › 4-digit display readout
- › Digital display in Celsius or Fahrenheit
- › Free temperature setting on the display
- › Display of current interior temperature
- › Status and error indication by 2 separate LEDs
- › Memory function saves the last settings

Note:

For temperature controlled transport, CoolFreeze coolers can optionally be fitted with a highly sensitive electronic system. Complemented by further models of your choice (see pages 26 – 27) they convert into customised solutions quickly and cost-effectively.

2 High quality materials

Injection-moulded cabinets and housings; all materials CFC-free

3 Perfect workmanship

Optimal functionality, long service life

4 Cooling technology at its best

Danfoss BDF compressors; integrated voltage monitor

5 Universal power supply

12/24 volts DC and 100 – 240 volts AC; suitable for solar operation

6 Comfort and convenience

Ergonomically shaped recessed grips, sturdy carrying handles, well-organised interior

Extras available as standard

Interior light

Wide choice of accessories

Insulating protective covers, universal fixing kit (p. 25)

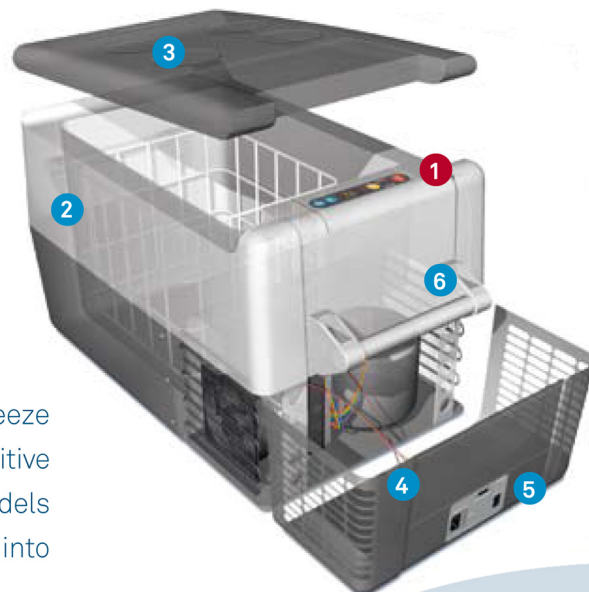

Compressor Coolers

1300 798 380

www.thermalmark.com.au

TMR *We Keep it Cool*
Thermal Mark
Transport Refrigeration

WAECO CoolFreeze CDF

The new compact class

The new compact class

From now on WAECO compressor technology is also available in a **10.5-litre compact class**. The new **WAECO CoolFreeze CDF-11** comes in a size that previously seemed impossible. Compact, handy and space-saving like a thermoelectric unit. Only 8.8 kg in weight and comfortable to carry with the shoulder strap. Powerful cooling from +10°C to -18°C.

Custom configuration with extra modules (pages 26 – 27).



Super-compact

WAECO CoolFreeze CDF-11

Portable compressor cooler for refrigeration and deep-freezing



Gross capacity	approx. 10.5 litres
Voltage	12/24 volts DC
Power input	approx. 30 watts
Power consumption	0.36 kWh/24 h
Temperature range	+10°C to -18°C, continuously variable via electronic thermostat
Insulation	CFC-free polyurethane foam
System	Compressor with integrated control electronics, low voltage protection (can be disabled), electronic fuse/automatic reverse pole protection
Material	Housing and lid PP
Colour	Pale grey/dark grey
Weight	approx. 8.8 kg
Quality features	Electronic thermostat with digital temperature display, 3-stage battery monitor, LED interior light, adjustable shoulder strap, two drink holders, easy and secure fastening with the vehicle safety belt
Scope of delivery	DC connection cable
Test mark	CE, e-approved to 2006/28/EC (Automotive EMC Directive)
Product	Ref. No.
CoolFreeze CDF-11	9105100007
Optional extras	
Mains adapter 230 V > 24 V	EPS-100W

4.29

NEW

Temperature range +10°C to -18°C

Suitable for solar operation

Extremely compact design

Two integrated drink holders

Securely fastened in a vehicle using the vehicle's own seat belts



Two practical drink holders, convenient access with one hand



Well organised interior with two separate compartments



Display with digital temperature readout



Connection cable for 12/24 volts DC, battery monitor can be disabled

1300 798 380
www.thermalmark.com.au



WAECO CoolFreeze CDF-18 / CDF-18T

Portable compressor cooler for refrigeration and deep-freezing



CDF-18

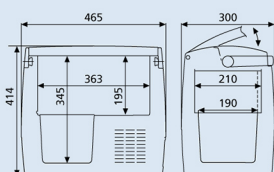

CDF-18T

**WAECO CoolFreeze CDF-25**

Compressor cooler for refrigeration and deep-freezing

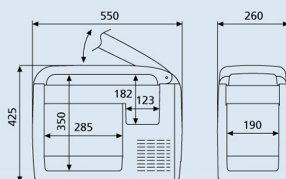

Gross capacity	approx. 18 litres
Voltage	12/24 volts DC
Power input	approx. 35 watts
Average running time	10% at +20°C ambient temperature 18% at +32°C ambient temperature both at +5°C interior temperature
Power consumption	Power input x average running time
Temperature range	+10°C to -18°C, continuously variable via electronic thermostat
Insulation	CFC-free PU foam
System	Compressor with integrated control electronics, low-voltage protection adjustable for leisure or starter battery by means of a slide switch, electronic fuse/automatic reverse pole protection, dynamically ventilated wire tube condenser, aluminium rollbond evaporator
Material	Cabinet: PP; lid: PE
Colour	Body: pale grey/dark grey; lid: dark grey
Weight	approx. 11.5 kg
Quality features	Detachable fold-up lid, sturdy carrying handle, vertical space for standing 2-litre bottles
Scope of delivery	DC connection cable
Test marks	CE, TÜV/GS, e-approved to 2006/28/EC (Automotive EMC Directive)

Product	Ref. No.
CoolFreeze CDF-18	9105100002
CoolFreeze CDF-18T (including trolley)	9105100006
Optional extras	
Mains adapter 230 V > 24 V	EPS-100W
Insulating protective cover	IC-CF-18

Temperature range
+10°C to -18°CSuitable for
solar operation

Energy saver:
short running times
with reinforced
insulation:
consumes only 0.29
Ah/h to reach +5°C
interior temperature
at +20°C ambient
temperature

Insulating protective
cover as accessory
(page 25)230-volt connection
with low-priced
mains adapters

Gross capacity	approx. 23 litres (19 l for refrigeration/deep-freezing, 4 l for fresh food)
Voltage	12/24 volts DC
Power input	approx. 35 watts
Average running time	15% at +20°C ambient temperature 19% at +32°C ambient temperature both at +5°C interior temperature
Power consumption	Power input x average running time
Temperature range	+10°C to -18°C, continuously variable via electronic thermostat
Insulation	CFC-free PU foam
System	Compressor with integrated control electronics, low voltage protection adjustable for leisure and starter battery by means of a slide switch, electronic fuse/automatic reverse pole protection, dynamically ventilated wire tube condenser, aluminium rollbond evaporator
Material	Cabinet: PP, lid: PE
Colour	Body: pale grey/dark grey; lid: dark grey
Weight	approx. 12.5 kg
Quality features	Detachable lid (lid mount at the front), vertical space for standing 2-litre bottles, interior light
Scope of delivery	DC connection cable, detachable wire basket
Test marks	CE, TÜV/GS, e-approved to 2006/28/EC (Automotive EMC Directive)

Product	Ref. No.
CoolFreeze CDF-25	9105100003
Optional extras	
Mains adapter 230 V > 24 V	EPS-100W
Universal fixing kit	UFC-C
Insulating protective cover	IC-CF-25

Temperature range
+10°C to -18°CSuitable for
solar operationSlim body –
minimal space
consumptionInsulating protective
cover and fixing kit as
accessories
(page 25)230-volt connection
with low-priced
main adapter

1300 798 380

www.thermalmark.com.au

TMR We Keep it Cool
Thermal Mark
 Transport Refrigeration

Truly independent

Integrated battery-run compressor cooler

WAECO **CoolFreeze CF-32UP** provides refrigeration and deep-freezing up to -18°C . And that's for **up to 18 hours without an external power supply**. Energy is supplied by the integrated battery which is simply enabled as and when required on a separate control panel. The LED display indicates the charging state. There are two options for battery recharging: 12- or 24-volt vehicle battery, or 230-volt mains (mains adapter comes as an accessory).



18 hours cooling without power supply

WAECO CoolFreeze CF-32UP

Compressor cooler/freezer with rechargeable battery

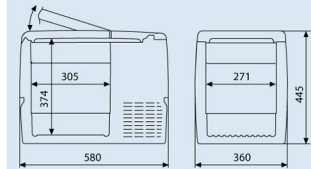

Gross capacity	approx. 31 litres
Voltage	12/24 volts DC
Power input	approx. 45 watts (cooling only) approx. 72 watts (cooling and charging)
Charging time	12 to 15 hours
Operation with battery	Up to 18 hours with fully charged battery at $+5^{\circ}\text{C}$ interior and $+32^{\circ}\text{C}$ ambient temperature
Average running time	18% at $+20^{\circ}\text{C}$ ambient temperature 22% at $+32^{\circ}\text{C}$ ambient temperature both at $+5^{\circ}\text{C}$ interior temperature
Power consumption	Power input x average running time
Temperature range	$+10^{\circ}\text{C}$ to -18°C , continuously variable via electronic thermostat with digital temperature display
Insulation	CFC-free PU foam
System	Fully hermetic Danfoss BD35F compressor with integrated control electronics, low-voltage protection, electronic fuse/automatic reverse pole protection, dynamically ventilated wire tube condenser, aluminium rollbond evaporator
Material	Cabinet: PP; lid: PE
Colour	Body: pale grey/dark grey; lid: dark grey
Weight	approx. 24 kg
Quality features	Intelligent battery monitor to prevent excessive discharging of the vehicle battery, display with digital temperature readout, temperature adjustable with two buttons in 1°C steps, simultaneous charging and cooling, battery charging state indicated by LED, battery low warning
Scope of delivery	DC connection cable, wire basket, detachable carrying handles
Test marks	CE, TÜV/GS, E-approved according to UN-ECE R10 directive
Product	Ref. No.
CoolFreeze CF-32UP	9105100001
Optional extras	
Mains adapter 110 – 240 V > 24 V	MPS-50
Universal fixing kit	UFK-C

4.10

NEW



Temperature range
 $+10^{\circ}\text{C}$ to -18°C



Suitable for
solar operation

With integrated battery
for up to 18 hours
operation without
external power

Fixing kit as
accessory
(page 25)



An extra control panel
for the battery:
ON/OFF switch,
LED display showing the
battery charging state

1300 798 380

www.thermalmark.com.au

TMR *We Keep it Cool*

Thermal Mark
Transport Refrigeration

WAECO CoolFreeze CF-35

Compressor cooler for refrigeration and deep-freezing with CF special electronics

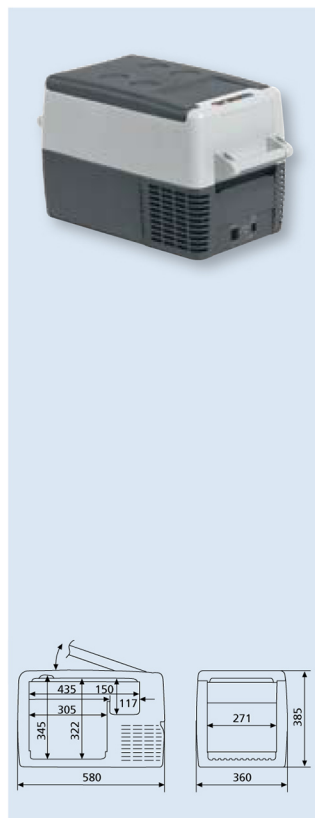

Gross capacity	approx. 31 litres (26.5 l for refrigeration/deep-freezing, 4.5 l for fresh food)
Voltage	12/24 volts DC and 100 – 240 volts AC
Power consumption	approx. 45 watts
Average running time	15% at +20°C ambient temperature 19% at +32°C ambient temperature both at +5°C interior temperature
Power consumption	Power input x average running time
Temperature range	+10°C to –18°C, free temperature setting via electronic thermostat with digital temperature readout
Insulation	CFC-free PU foam
System	Fully hermetic Danfoss BD35F compressor with integrated control electronics, low voltage protection adjustable for leisure and starter battery via electronic system, electronic fuse/automatic reverse pole protection, dynamically ventilated wire tube condenser, aluminium rollbond evaporator
Material	Cabinet: PP, lid: PE
Colour	Body: pale grey/dark grey; lid: dark grey
Weight	approx. 15 kg
Quality features	Detachable lid (lid mount at the front), interior light, vertical space for standing 1.5-litre bottles. CF special electronics with soft start and turbo cooler
Scope of delivery	DC and AC connection cables, evaporator grille, detachable carrying handles
Test marks	CE, TÜV/GS, e-approved to 2006/28/EC (Automotive EMC Directive)
Product	Ref. No.
CoolFreeze CF-35	CF-035AC
Optional extras	
Universal fixing kit	UFK-C
Insulating protective cover	IC-CF-35

Temperature range
+10°C to –18°CSuitable for
solar operation12/24 volts DC and
100 – 240 volts ACProtective cover,
and fixing kit
as accessories
(page 25)**WAECO CoolFreeze CF-40**

Compressor cooler for refrigeration and deep-freezing with CF special electronics

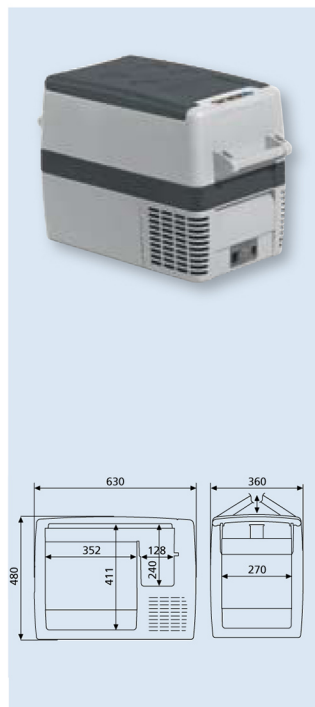

Gross capacity	approx. 37 litres (31 l for refrigeration/deep-freezing, 6 l for fresh food)
Voltage	12/24 volts DC and 100–240 volts AC
Power input	approx. 45 watts
Average running time	18% at +20°C ambient temperature 22% at +32°C ambient temperature both at +5°C interior temperature
Power consumption	Power input x average running time
Temperature range	+10°C to –18°C, free temperature setting via electronic thermostat with digital temperature readout
Insulation	CFC-free PU foam
System	As for CF-35
Material	Cabinet: PP, lid: PE
Colour	Body: pale grey/dark grey, lid: dark grey
Weight	approx. 16 kg
Quality features	Detachable lid (lid mount at the front), interior light, vertical space for standing 2-litre bottles. CF special electronics with soft start and turbo cooler
Scope of delivery	DC and AC connection cables, removable wire basket, detachable carrying handles
Test marks	CE, TÜV/GS, e-approved to 2006/28/EC (Automotive EMC Directive)
Product	Ref. No.
CoolFreeze CF-40	CF-040AC
Optional extras	
Universal fixing kit	UFK-C
Insulating protective cover	IC-CF-40

CF special electronics
with soft start and
turbo cooler1300 798 380
www.thermalmark.com.au

Thermal Mark
Transport Refrigeration

WAECO CoolFreeze CF-50

Compressor cooler for refrigeration and deep-freezing with CF special electronics

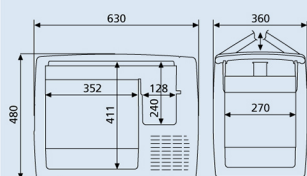

Gross capacity	approx. 49 litres (41 l for refrigeration/deep-freezing, 8 l for fresh food)
Voltage	12/24 volts DC and 110 – 240 volts AC
Power input	approx. 45 watts
Average running time	15% at +20°C ambient temperature 19% at +32°C ambient temperature both at +5°C interior temperature
Power consumption	Power input x average running time
Temperature range	+10°C to –18°C, free temperature setting via electronic thermostat with digital temperature readout
Insulation	CFC-free PU foam
System	As for CF-35
Material	Cabinet: PP, lid: PE
Colour	Body: pale grey/dark grey; lid: dark grey
Weight	approx. 18 kg
Quality features	Detachable lid (plug-in lid mount, variable left/right), interior light, vertical space for standing 2-litre bottles. CF special electronics with soft start and turbo cooler
Scope of delivery	As for CF-40
Test marks	CE, TÜV/GS, e-approved to 2006/28/EC (Automotive EMC Directive)
Product	Ref. No.
CoolFreeze CF-50	CF-050AC
Optional extras	
Universal fixing kit	UFK-C
Insulating protective cover	IC-CF-50



Temperature range
+10°C to –18°C



Suitable for
solar operation



12/24 volts DC and
100 – 240 volts AC

Protective cover
and fixing kit as
accessories
(page 25)

CF-50/CF-60:
Detachable lid,
folds up transversely,
variable lid mounts

WAECO CoolFreeze CF-60

Compressor cooler for refrigeration and deep-freezing with CF special electronics

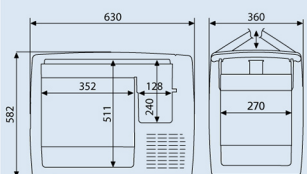

Gross capacity	approx. 59 litres (51 litres for refrigeration/deep-freezing, 8 litres for fresh food)
Voltage	12/24 volts DC and 110 – 240 volts AC
Power input	approx. 45 watts
Average running time	18% at +20°C ambient temperature, 22% at +32°C ambient temperature, both at +5°C interior temperature
Power consumption	Power input x average running time
Temperature range	+10°C to –18°C, free temperature setting via electronic thermostat with digital temperature readout
Insulation	CFC-free PU foam
System	As for CF-35
Material	Cabinet: PP, lid: PE
Colour	Body: pale grey/dark grey; lid: dark grey
Weight	approx. 21.6 kg
Quality features	Detachable lid (plug-in lid mount, variable left/right), interior light, vertical space for standing 2-litre bottles. CF special electronics with soft start and turbo cooler
Scope of delivery	DC and AC connection cables, removable wire basket, detachable carrying handles
Test marks	CE, TÜV/GS, e-approved to 2006/28/EC (Automotive EMC Directive)
Product	Ref. No.
CoolFreeze CF-60	CF-060AC
Optional extras	
Universal fixing kit	UFK-C
Insulating protective cover	IC-CF-60



CF special electronics
with soft start and
turbo cooler



1300 798 380

www.thermalmark.com.au



Thermal Mark
Transport Refrigeration

WAECO CoolFreeze CF-80

Large-capacity cooler for refrigeration and deep-freezing with CF special electronics

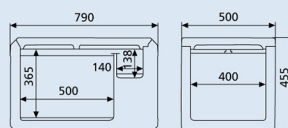

Gross capacity	approx. 80 litres (73 l for refrigeration/deep-freezing, 7 l for fresh food)
Voltage	12/24 volts DC and 100 – 240 volts AC
Power input	approx. 65 watts
Average running time	12% at +20°C ambient temperature 22% at +32°C ambient temperature both at +5°C interior temperature
Power consumption	Power input x average running time
Temperature range	+10°C to –18°C, free temperature setting via electronic thermostat with digital temperature readout
Insulation	CFC-free PU foam
System	Fully hermetic Danfoss BD50F compressor with integrated control electronics, low voltage protection adjustable for leisure and starter battery via electronic system, electronic fuse/automatic reverse pole protection, dynamically ventilated fin condenser, aluminium rollbond evaporator
Material	Cabinet: coated sheet steel, top and base: PP, lid: PE
Colour	Body: pale grey/dark grey, lid: pale grey
Weight	approx. 31 kg
Quality features	Detachable lid (screw-on lid mount, variable left/right), sturdy latches and hinges, interior light, vertical space for 2-litre bottles. CF special electronics with soft start and turbo cooler
Scope of delivery	DC and AC connection cables, removable wire basket, detachable carrying handles
Test marks	CE, TÜV/GS, e-approved to 2006/28/EC (Automotive EMC Directive)

Product	Ref. No.
CoolFreeze CF-80	CF-080AC
Optional extras	
Insulating protective cover	IC-CF-80

Temperature range
+10°C to –18°CSuitable for
solar operation12/24 volts DC and
100 – 240 volts ACJumbo coolers
for personal and
professional useProtective cover
as accessory
(page 25)**WAECO CoolFreeze CF-110**

Large-capacity cooler for refrigeration and deep-freezing with CF special electronics

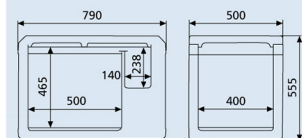

Gross capacity	approx. 106 litres (93 l for refrigeration/deep-freezing, 13 l for fresh food)
Voltage	12/24 volts DC and 100 – 240 volts AC
Power input	approx. 65 watts
Average running time	14% at +20°C ambient temperature 25% at +32°C ambient temperature both at +5°C interior temperature
Power consumption	Power input x average running time
Temperature range	+10°C to –18°C, free temperature setting via electronic thermostat with digital temperature readout
Insulation	CFC-free PU foam
System	As for CF-80
Material	Cabinet: coated sheet steel, top and base: PP, lid: PE
Colour	Body: pale grey/dark grey, lid: pale grey
Weight	approx. 33 kg
Quality features	Detachable lid (screw-on lid mount, variable left/right), sturdy latches and hinges, interior light, vertical space for 2-litre bottles. CF special electronics with soft start and turbo cooler
Scope of delivery	DC and AC connection cables, removable wire basket, detachable carrying handles
Test marks	CE, TÜV/GS, e-approved to 2006/28/EC (Automotive EMC Directive)

Product	Ref. No.
CoolFreeze CF-110	CF-110AC
Optional extras	
Insulating protective cover	IC-CF-110

CF special electronics
with soft start and
turbo cooler

1300 798 380
www.thermalmark.com.au

TMR We Keep it Cool
Thermal Mark
Transport Refrigeration

Deep-freezing up to – 24°C

For safety's sake

For the storage and transport of ice-cream, a deep-freeze temperature of **at least –21 °C** is stipulated by law – which means a standard compressor cooler just won't do. To be on the safe side, opt for the new WAECO CoolFreeze FC-30TK. It performs **up to –24°C** and gives you a full 30-litre deep-freeze capacity for your temperature sensitive freight.

Useful accessories: wire basket to organise the interior, fixing kit for a secure hold during the drive, high-quality insulating protective cover.



WAECO CoolFreeze FC-30TK

Compressor deep-freezer

4.12

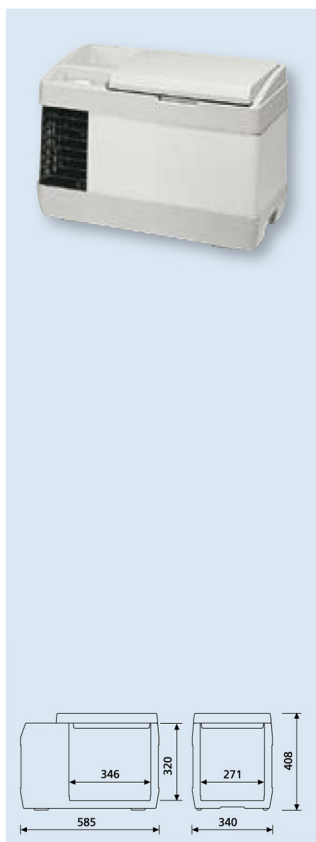

Gross capacity	approx. 30 litres
Voltage	12/24 volts DC
Power input	approx. 60 watts
Average running time	40% at +20°C ambient temperature, 60% at +32°C ambient temperature, both at –18°C interior temperature
Power consumption	Power input x average running time
Temperature range	–10°C to –24°C
Insulation	30 mm polyurethane foam
System	Fully hermetic Danfoss BD35F compressor with integrated control electronics, low voltage protection adjustable for leisure and starter battery by means of a slide switch, electronic fuse/automatic reverse pole protection, dynamically ventilated wire tube condenser, aluminium rollbond evaporator, continuously variable thermostat
Material	Body: sheet steel; base, lid and upper part of the cabinet: embossed plastic (polystyrene)
Colour	Body: pale grey, powder-coated; lid and upper part of the cabinet: grey/white
Weight	16.0 kg
Scope of delivery	DC connection cable
Test marks	CE

Product	Ref. No.
CoolFreeze FC-30TK	9105100005
Optional extras	
Wire basket for FC-30TK	W529.3
Protective cover for FC-30TK	IC-FF30
Universal fixing kit	W1440.ST
Mains adapter 110 – 240 V > 24 V	MPS-50



Temperature range
–10°C to –24°C

Continuously
variable

Wire basket, protective
cover and fixing kits as
optional extras

1300 798 380

www.thermalmark.com.au

Accessories for CoolFreeze coolers

Designed for safe and convenient handling

Tailor-made protective covers with insulating effect and a universal fastening device that keeps the cooler firmly in place while driving – **WAECO CoolFreeze accessories give you more functionality, safety and user comfort.**

Insulating protective covers

4.10

For CoolFreeze CDF-18, CDF-25, CF-35, CF-40, CF-50, CF-60, CF-80, CF-110



Material, outside	High-quality silver-grey Oxford nylon, lid and base in robust, rubber coated, black nylon
Material, inside	Aluminium coated polyester
Colour, sides	Silver grey
Colour, lid and base	Black
Quality features	Detachable lid and base, outside pockets to store small items, four fixing rings to secure the box safely in the vehicle

Extra protection and insulation for your cooler

Product	Weight (kg)	Ref. No.
Protective cover for CoolFreeze CDF-18	approx. 1.0	IC-CF-18
Protective cover for CoolFreeze CDF-25	approx. 1.1	IC-CF-25
Protective cover for CoolFreeze CF-35	approx. 1.3	IC-CF-35
Protective cover for CoolFreeze CF-40	approx. 1.5	IC-CF-40
Protective cover for CoolFreeze CF-50	approx. 2.0	IC-CF-50
Protective cover for CoolFreeze CF-60	approx. 2.0	IC-CF-60
Protective cover for CoolFreeze CF-80	approx. 2.2	IC-CF-80
Protective cover for CoolFreeze CF-110	approx. 2.4	IC-CF-110

Universal fixing kit

4.10

For CoolFreeze CDF-25, CF-35, CF-40, CF-50, CF-60
For fastening of WAECO CoolFreeze coolers in vehicles

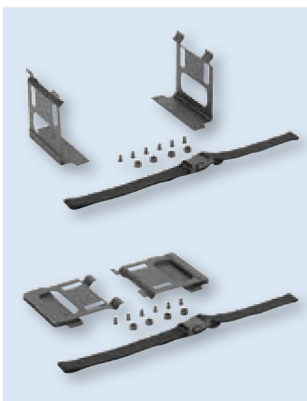

Material/Colour	Powder coated metal
Colour	Black
Scope of delivery	Two frame sections, adjustable strap with snap lock, set of screws

For a firm and secure hold in the vehicle

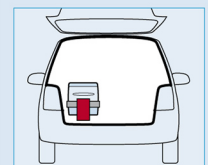

Product	Ref. No.
Universal fixing kit	UFK-C

1300 798 380
www.thermalmark.com.au

Made to measure from modules

Well-proven compressor technology plus special modules of your choice – it takes just a few easy steps to create your own customised box. Start by choosing the right-sized appliance from our standard programme (10.5 to 106 litres, p. 18 – 23), then combine it with the extra modules you need.

Remote monitoring by GSM – documentation with data logger



Eutectic cooling and/or GSM

Eutectic cooling is ideal for long-term, temperature controlled transport of high-quality products without external power supply (e.g. by air or rail). Prior to transportation, the box is pre-cooled on the mains to achieve the factory preset fixed temperature. Cooling then works without power supply. The temperature is reliably maintained up to 35 hours (at ambient temperatures up to +30°C.) Ideal add-on: the GSM module, which can be used to send a text containing the current inside and outside temperature information to the retrieving mobile phone number or e-mail address.

Note: Retrofitting the eutectic module reduces the net capacity and increases the weight of CoolFreeze standard boxes.

Documentation

For the sake of continuous, tamper-proof temperature recording the data logger is firmly integrated in the cooler. Data can be transferred to a laptop computer via a data cable with infrared interface – or printed out directly using the attachable printer.

Extra modules available for compressor coolers

Compressor-coolers Temperature range +10°C to -18°C	DT-01 Digital temperature readout	DT-02 One factory preset fixed temperature	DT-03 Variable temperature	DT-04 Interior fan	DT-05 Heater with three- point controller	DT-06 Digital radio thermo- meter	DT-07 Data logger with software and USB	DT-08 Thermal printer	DT-09 Two factory preset fixed tempera- tures	DT-10 Eutectic cooling	DT-11 GSM module	DT-12 Data logger as single unit without software	DT-13 3-pin plug-in system
CDF-11 approx. 10.5 litres	●	●		●		●	●	●	●			●	●
CDF-18 approx. 18 litres	●	●	●	●	●	●	●	●	●			●	●
CDF-25 approx. 23 litres	●	●				●	●	●	●			●	●
CF-32UP approx. 31 litres	●	●	●			●	●	●	●			●	●
CF-35 approx. 31 litres	●	●	●			●	●	●	●			●	●
CF-40 approx. 37 litres	●	●	●			●	●	●	●			●	●
CF-50 approx. 49 litres	●	●	●			●	●	●	●	●	●	●	●
CF-60 approx. 59 litres	●	●	●			●	●	●	●	●	●	●	●
CF-80 approx. 80 litres	●	●	●	●	●	●	●	●	●	●	●	●	●
CF-110 approx. 106 litres	●	●	●	●	●	●	●	●	●	●	●	●	●

1300 798 380

www.thermalmark.com.au



Thermal Mark
Transport Refrigeration

Extra modules for compressor coolers

	<p>DT-01 Digital readout of the current temperature inside the box. Replaces the soft-touch operating panel of the CF standard boxes.</p> <table border="1"> <thead> <tr> <th>Product</th> <th>Ref. No.</th> </tr> </thead> <tbody> <tr> <td>Digital temperature readout</td> <td>DT-01</td> </tr> </tbody> </table>	Product	Ref. No.	Digital temperature readout	DT-01		<p>DT-08 Attachable mini-printer for real-time, on-site documentation</p> <table border="1"> <thead> <tr> <th>Product</th> <th>Ref. No.</th> </tr> </thead> <tbody> <tr> <td>Thermal printer</td> <td>DT-08</td> </tr> </tbody> </table>	Product	Ref. No.	Thermal printer	DT-08
Product	Ref. No.										
Digital temperature readout	DT-01										
Product	Ref. No.										
Thermal printer	DT-08										
	<p>DT-02 One fixed temperature in a range from -18°C to $+10^{\circ}\text{C}$ preset in the factory. Tolerance: $\pm 2^{\circ}\text{C}$ (independent of outside temperature; closer upon request). Test log supplied as standard.</p> <table border="1"> <thead> <tr> <th>Product</th> <th>Ref. No.</th> </tr> </thead> <tbody> <tr> <td>One factory preset fixed temperature</td> <td>DT-02</td> </tr> </tbody> </table>	Product	Ref. No.	One factory preset fixed temperature	DT-02		<p>DT-09 Two preset fixed temperatures in a range from -18°C to $+10^{\circ}\text{C}$. Easy change from one value to another with rocker switch. Tolerance: $\pm 2^{\circ}\text{C}$ (independent of outside temperature; closer upon request). Test log supplied as standard.</p> <table border="1"> <thead> <tr> <th>Product</th> <th>Ref. No.</th> </tr> </thead> <tbody> <tr> <td>Two factory preset fixed temperatures</td> <td>DT-09</td> </tr> </tbody> </table>	Product	Ref. No.	Two factory preset fixed temperatures	DT-09
Product	Ref. No.										
One factory preset fixed temperature	DT-02										
Product	Ref. No.										
Two factory preset fixed temperatures	DT-09										
	<p>DT-03 Temperature variable in a range from -18°C to $+10^{\circ}\text{C}$ with temperature controller. Control electronics reliably compensate for deviations from preset value. Tolerance: $\pm 2^{\circ}\text{C}$ (closer upon request).</p> <table border="1"> <thead> <tr> <th>Product</th> <th>Ref. No.</th> </tr> </thead> <tbody> <tr> <td>Variable temperature</td> <td>DT-03</td> </tr> </tbody> </table>	Product	Ref. No.	Variable temperature	DT-03		<p>DT-10 Eutectic cooling for CoolFreeze CF-50, CF-80, CF-110. Cooler is pre-cooled on the mains to the factory preset temperature level, which is maintained for up to 35 hours without energy supply (at ambient temperatures up to $+30^{\circ}\text{C}$).</p> <table border="1"> <thead> <tr> <th>Product</th> <th>Ref. No.</th> </tr> </thead> <tbody> <tr> <td>Eutectic cooling</td> <td>DT-10</td> </tr> </tbody> </table>	Product	Ref. No.	Eutectic cooling	DT-10
Product	Ref. No.										
Variable temperature	DT-03										
Product	Ref. No.										
Eutectic cooling	DT-10										
	<p>DT-04 High-performance fan for fast cooling or heating and uniform air circulation inside the box.</p> <table border="1"> <thead> <tr> <th>Product</th> <th>Ref. No.</th> </tr> </thead> <tbody> <tr> <td>Interior fan</td> <td>DT-04</td> </tr> </tbody> </table>	Product	Ref. No.	Interior fan	DT-04		<p>DT-11 GSM module for remote monitoring</p> <table border="1"> <thead> <tr> <th>Product</th> <th>Ref. No.</th> </tr> </thead> <tbody> <tr> <td>GSM module</td> <td>DT-11</td> </tr> </tbody> </table>	Product	Ref. No.	GSM module	DT-11
Product	Ref. No.										
Interior fan	DT-04										
Product	Ref. No.										
GSM module	DT-11										
	<p>DT-05 Extra heater for safer operation at low outside temperatures. Also for compressor coolers to be equipped with additional heating function.</p> <table border="1"> <thead> <tr> <th>Product</th> <th>Ref. No.</th> </tr> </thead> <tbody> <tr> <td>Heater with three-point-controller</td> <td>DT-05</td> </tr> </tbody> </table>	Product	Ref. No.	Heater with three-point-controller	DT-05		<p>DT-12 Data logger as single unit, without software.</p> <table border="1"> <thead> <tr> <th>Product</th> <th>Ref. No.</th> </tr> </thead> <tbody> <tr> <td>Data logger as single unit without software</td> <td>DT-12</td> </tr> </tbody> </table>	Product	Ref. No.	Data logger as single unit without software	DT-12
Product	Ref. No.										
Heater with three-point-controller	DT-05										
Product	Ref. No.										
Data logger as single unit without software	DT-12										
	<p>DT-06 Digital radio thermometer transmits current temperature to the dashboard-mounted display unit (display unit included in the delivery kit).</p> <table border="1"> <thead> <tr> <th>Product</th> <th>Ref. No.</th> </tr> </thead> <tbody> <tr> <td>Digital radio thermometer</td> <td>DT-06</td> </tr> </tbody> </table>	Product	Ref. No.	Digital radio thermometer	DT-06		<p>DT-13 3-pin plug-in system for built-in power supply. Max. current consumption: 25 A at 6 – 24 volts. Flat terminals (4 x 6.3 mm, 1 x 4.8 mm).</p> <table border="1"> <thead> <tr> <th>Product</th> <th>Ref. No.</th> </tr> </thead> <tbody> <tr> <td>3-pin plug-in system</td> <td>2225400001</td> </tr> </tbody> </table>	Product	Ref. No.	3-pin plug-in system	2225400001
Product	Ref. No.										
Digital radio thermometer	DT-06										
Product	Ref. No.										
3-pin plug-in system	2225400001										
	<p>DT-07 Data logger with software and USB connection for continuous recording of the temperature.</p> <table border="1"> <thead> <tr> <th>Product</th> <th>Ref. No.</th> </tr> </thead> <tbody> <tr> <td>Data logger with software and USB</td> <td>DT-07</td> </tr> </tbody> </table>	Product	Ref. No.	Data logger with software and USB	DT-07						
Product	Ref. No.										
Data logger with software and USB	DT-07										

WAECO CoolFreeze

WAECO CoolMatic MH-07
7 litres capacity



WAECO CoolMatic MR-07
7 litres capacity



+4°C compressor cooling or
+40°C heating

According to
DIN 75079



Mobile, hygienic, perfect in every detail

Stainless-steel built-in cabinets with compressor cooling or heating

Cooling or heating with $\pm 2^\circ\text{C}$ accuracy: WAECO's innovative generation of refrigerator and warmer cabinets was specifically designed **for use in emergency vehicles.**

The interior temperature is limited at $+4^\circ\text{C}$ or, respectively, $+40^\circ\text{C}$ (tolerance: $\pm 2^\circ\text{C}$). This, combined with well thought-out details, qualifies the cabinets for other applications, too.



Built-in functionality: digital temperature read-out in the stainless steel installation frame



Transport-proof: catches that keep the door tightly closed even in inclined positions



Ideal in confined spaces: detachable cooling unit with 1.5-metre supply cable (MR-07)



Adjustable interior: The height of the grid shelf can be varied in three steps.

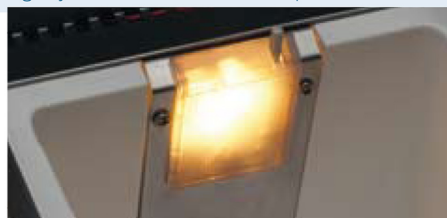

No mixing up of items: well illuminated interior



Inner values: water drainage, additional fan for optimal temperature distribution

1300 798 380
www.thermalmark.com.au

TMR
We Keep it Cool
Thermal Mark
Transport Refrigeration

WAECO CoolMatic MR-07

Compressor built-in refrigerator with stainless steel front. Fixed point temperature preset at +4°C (tolerance ± 2°C)

4.09

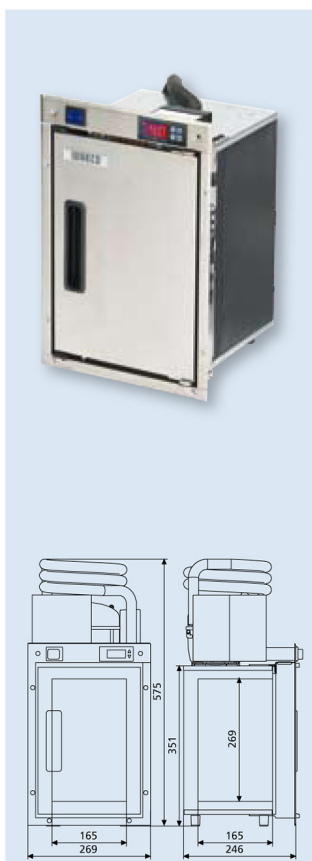

Gross capacity	approx. 7 litres
Voltage	12 volts DC
Average power consumption	approx. 36 watts
Temperature range	Fixed point temperature preset at +4°C (± 2°C)
Insulation	Polyurethane/CFC-free
System	Fully hermetic Danfoss BD35F compressor with integrated control electronics, low-voltage protection, electronic fuse/automatic reverse pole protection, dynamically ventilated wire tube condenser, three-face rear wall evaporator foamed from behind
Material	Door and flush-mount installation frame: stainless steel; Interior: plastic
Colour	Front: silver; interior: white
Weight	approx. 10 kg
Quality features	Fixed point temperature at +4°C (± 2°C), optimal temperature distribution with additional fan integrated in the inside rear wall, digital temperature display integrated in the stainless steel installation frame, interior light, grid shelf height adjustable in three positions, recessed door grip, variable door mounts and locks (left/right), ON/OFF switch. Where space is limited, the cooling unit can be fitted to the side of the cabinet (right or left), or up to 1.5 metres away.
Test marks	CE, e-approved to 2006/96/EC (Automotive EMC Directive)

Product	Ref. No.
CoolMatic MR-07	MR-07-12



+4°C
fixed point
temperature (± 2°C)



12 volts DC

Certified according to
DIN 75079

Cooling unit can be
fitted separately

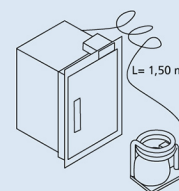

WAECO CoolMatic MH-07

Built-in warmer cabinet with stainless steel front. Fixed point temperature preset at +40°C (tolerance ± 2°C)

4.09

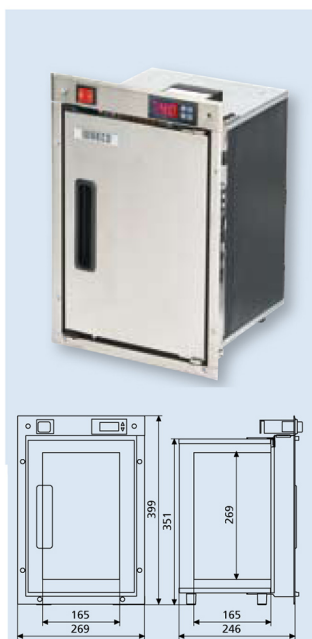

Gross capacity	approx. 7 litres
Voltage	12 volts DC
Average power consumption	approx. 15 to 20 watts
Temperature range	Fixed point temperature preset at +40°C (± 2°C)
Insulation	Polyurethane/CFC-free
System	12-volt heating resistor
Material	Door and flush-mount installation frame: stainless steel; Interior: plastic
Colour	Front: silver; interior: white
Weight	approx. 4.5 kg
Quality features	Fixed point temperature at +40°C (± 2°C), optimal temperature distribution with additional fan integrated in the inside rear wall, digital temperature display integrated in the stainless steel installation frame, interior light, grid shelf height adjustable in three positions, recessed door grip, variable door mounts and locks (left/right), ON/OFF switch.
Test marks	CE, e-approved to 2006/96/EC (Automotive EMC Directive)

Product	Ref. No.
CoolMatic MH-07	MH-07-12



+40°C
fixed point
temperature (± 2°C)



12 volts DC

Certified according to
DIN 75079

1300 798 380
www.thermalmark.com.au

Compressor built-in cooler

High performance, compact size

About 5 litres storage for temperature-sensitive freight is provided by the WAECO CoolFreeze MC-045. High-performance compressor technology and the factory preset fixed temperature of +5°C qualify this cooler for temperature controlled transport. With its compact outside dimensions it can be fitted almost anywhere in the vehicle. The detachable cooling unit can be installed up to 0.5 metres away from the cooler.



WAECO CoolFreeze MC-045

Compressor built-in cooler

4.09

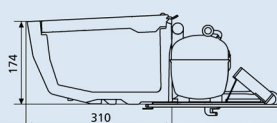
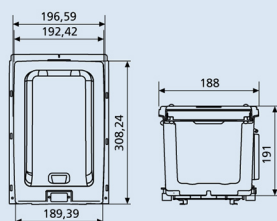

Gross capacity	approx. 4.5 litres
Voltage	12 volts DC
Average power consumption	45 watts, depending on the ambient temperature
Temperature range	Fixed point temperature preset at +5°C
Insulation	Polyurethane/CFC-free
System	Fully hermetic Danfoss BD35F compressor with integrated control electronics, low-voltage protection, electronic fuse/automatic reverse pole protection, aluminium heat exchanger with dynamic air circulation
Material	Outside: Styrofoam; inside: PVC
Dimensions (W x D)	192.42 x 308.24 mm (cut-out for installation)
Weight	approx. 1.5 kg
Quality features	Fixed temperature factory preset at +5 °C, ON/OFF switch, LED status indication Where space is limited the cooling unit can be fitted up to 0.5 metres away from the cooler.
Test marks	e-approved to 2006/28/EC (Automotive EMC Directive)

Product	Ref. No.
CoolFreeze MC-045	9105100004



+5°C
fixed point
temperature



12 volts

Certified according to
DIN 75079

Cooling unit can be
fitted apart

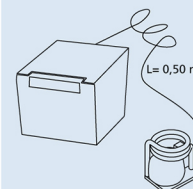

1300 798 380

www.thermalmark.com.au



Warm and cold food on the move

Ideal for transport over longer distances: the Dometic GB-24 PLUS keeps cold or warm food at the right temperature for at least twelve hours. The thermoelectric refrigerator and warmer cabinet was specifically designed for use with Gastronorm containers. It can optionally be fitted with feet or wheels. If required, two cabinets can be stacked on top of each other. Energy comes from a mains supply or the 12-volt vehicle battery, depending on the place of use.

Dometic GB-24 PLUS

Thermoelectric refrigerator and warmer cabinet for food transport over longer distances



Gross capacity	92 litres
Voltage	12 volts DC, 110 – 230 volts AC
Average power consumption	66 watts at 12 volts DC, 100 watts at 110 – 230 volts AC
Temperature range	+2°C to +5°C for refrigerated food +75°C to +80°C for warm food
Insulation	Polyurethane/CFC-free
System	Active, isothermal system with wear-free thermoelectric (Peltier element)
Material	HDPE (high-density polyethylene)
Colour	Grey
Dimensions (W x H x D)	510 x 705 x 785 mm (without wheels) 510 x 835 x 785 mm (with wheels)
Weight	26 kg
Quality features	Keeps food warm or cold for at least 12 hours, simple switch-over between refrigerator and warmer function, digital readout of the interior temperature, 2 cabinets can be stacked on top of each other, optional fitting with wheels or feet, detachable seal, door opening up to 270°, DIN A5 document holder
Test marks	CE, E1

Product	Ref. No.
Dometic GB-24 PLUS	991.6910.41
Optional extras	
Set of 2 rotating wheels, with brake & 2 fixed castors	296.1804.01
Adjustable stainless steel feet (4 pieces)	296.1804.00

4.25

NEW



12/110 – 230 volts

Keeps food warm or cold for at least 12 hours

Compatible with Gastronorm containers

7 tray levels (each spaced 57 mm apart)

1300 798 380
www.thermalmark.com.au



Mobile professionals for a continuous cold chain

Four transport containers for maintaining a continuous cold chain in professional kitchens – designed by Dometic Luxembourg, specialist in cooling solutions for catering and medical applications. All four units feature a high-performance compressor system and electronic regulation of the interior temperature. A battery-powered acoustic alarm system signals any deviation from the preset temperature.

Dometic R-120

Mobile compressor refrigerator fitted for catering use

4.25

NEW



At ambient temperatures of 16°C to 43°C:
Temperature range
+2°C to +10°C



12/24/110 – 230 volts

Specially designed to maintain the cold chain in professional kitchen use

Compatible with 400 x 600 mm Euronorm containers

Various configurations

Gross capacity	134 litres
Voltage	12/24 volts DC, 110 – 230 volts AC
Average power consumption	85 watts
Temperature range	Interior temperature can be set between +2°C and +10°C
Insulation	Polyurethane/CFC-free
System	Danfoss BD-50 compressor, electronic temperature regulation, air circulation in the interior
Material	HDPE (high-density polyethylene)
Colour	Grey
Outside dimensions (W x H x D)	565 x 710 x 950 mm
Inside dimensions (W x H x D)	430 x 500 x 605 mm
Weight	42 kg
Quality features	Electronic regulation of the interior temperature, battery-powered acoustic alarm for deviation from preset temperature, compatible with 400 x 600 mm Euronorm containers, various configurations possible, optional fitting with wheels or feet, stackable, detachable seal, DIN A5 document holder
Test marks	CE



Product	Ref. No.
Dometic R-120	958.4004.41
Optional extras	
GB-35 rack system for 400 x 600 mm GN containers/baking trays	296.3618.15*
Rack system for grill tray or drawers	296.3618.19*
Stainless steel grill tray and supports	296.3618.14
U-sections for Rack-01 rack system	296.3567.28*
* 2 pieces required in each case	

1300 798 380
www.thermalmark.com.au

Dometic RF-400 Mobile compressor refrigerator fitted for catering use

Gross capacity	370 litres
Voltage	230 volts AC
Average power consumption	180 watts (300 watts during the defrosting phase)
Temperature range	Interior temperature can be set between +10°C and -20°C
Insulation	Polyurethane/CFC-free
System	Compressor, electronic temperature regulation, air circulation in the interior
Material	HDPE (high-density polyethylene)
Colour	Grey
Outside dimensions (W x H x D)	790 x 1624 x 965 mm
Inside dimensions (W x H x D)	590 x 874 x 715 mm
Weight	136 kg
Quality features	Electronic regulation of the interior temperature, battery-powered acoustic alarm for deviation from preset temperature, automatic defrosting, rack system with 3 stainless steel grill trays to organise the interior, compatible with GN2/1 and GN1/1 Gastronorm containers, wheels with brakes, integrated grips for easy handling, detachable double seal, door opening up to 270° with latching, lockable door, easy replacement of the complete cooling unit
Test marks	CE

Dometic RF-650 Mobile compressor refrigerator fitted for catering use

Gross capacity	612 litres
Average power consumption	180 watts (300 watts during the defrosting phase)
Outside dimensions (W x H x D)	880 x 1900 x 1090 mm
Inside dimensions (W x H x D)	660 x 1130 x 820 mm
Weight	165 kg
Quality features	Electronic regulation of the interior temperature, battery-powered acoustic alarm for deviation from preset temperature, automatic defrosting, rack system with 3 stainless steel grill trays to organise the interior, compatible with 400 x 600 mm Euronorm containers and 600 x 800 mm baking trays, wheels with brakes, integrated grips for easy handling, detachable double seal, door opening up to 270° with latching, easy replacement of the complete cooling unit
Test marks	CE

Other specifications as for RF-400

Dometic RF-1000 Mobile compressor refrigerator fitted for catering use

Gross capacity	920 litres
Average power consumption	180 watts (300 watts during the defrosting phase)
Outside dimensions (W x H x D)	1030 x 1900 x 1275 mm
Inside dimensions (W x H x D)	810 x 1130 x 1005 mm
Weight	191 kg
Quality features	Electronic regulation of the interior temperature, battery-powered acoustic alarm for deviation from preset temperature, automatic defrosting, rack system with 3 stainless steel grill trays to organise the interior, wheels with brakes, integrated grips for easy handling, detachable double seal, door opening up to 270° with latching, easy replacement of the complete cooling unit
Test marks	CE

Other specifications as for RF-400

Product	Ref. No.
Dometic RF-400	958.4006.41
Dometic RF-650	958.4008.41
Dometic RF-1000	958.4010.41
Optional extras	
Extra grill tray for RF-400 (532 x 675 mm)	296.3618.12
Guide plate left/right for RF-400 (one each for one extra grill tray)	296.3567.09/296.3567.10
Extra grill tray for RF-650 (600 x 790 mm)	296.361.811
Guide plate left/right for RF-650 (one each for one extra grill tray)	296.3567.22/296.3567.23
Extra grill tray for RF-1000 (758 x 976 mm)	296.3618.06
Guide plate left/right for RF-1000 (one each for one extra grill tray)	296.3567.24/296.3567.25

NEW

At ambient temperatures of 16°C to 43°C:
Temperature range +10°C to -20°C



230 volts AC

Specially designed to maintain the cold chain in professional kitchen use

Dual fridge/freezer function

Automatic defrosting

Compatible with Gastronorm containers GN2/1 and GN1/1 (RF-400)

Compatible with 400 x 600 mm Euronorm containers and 600 x 800 mm baking trays (RF-650)

1300 798 380

www.thermalmark.com.au

TMR *We Keep it Cool*
Thermal Mark
Transport Refrigeration

The low-cost alternative to van conversion

With the compressor cooling container **WAECO CoolFreeze 850VAN** you can have a fully equipped refrigerated vehicle without cost-intensive van conversions. The spacious **850-litre container** is simply lashed to the cargo floor with straps and hooks. Energy for cooling comes from the **12-volt vehicle battery** or a **230-volt mains supply**. When external power supply is unavailable (e.g. in catering use), the preset temperature is maintained for several hours by the **integrated rechargeable 12-volt gel battery**. Another benefit of the retrofit solution: clean removal is possible at all times.

WAECO CoolFreeze 850VAN

Compressor cooling container for vans

4.25



Gross capacity	850 litres
Voltage	12 volts DC, 220 – 240 volts AC
Average power consumption	150 watts max. at 12 volts DC 220 watts max. at 220 – 240 volts AC (360 watts during battery charging)
Temperature range	0°C to +12°C
Insulation	Polyurethane, CFC-free
System	DC compressor with mains adapter and battery charger for integrated gel battery
Material	HDPE (high-density polyethylene) / polyurethane
Colour	Grey
Dimensions (W x H x D)	1100 x 1000 x 1400 mm
Weight	160 kg
Quality features	Independent operation for up to 8 hours with battery integrated as standard, or up to 16 hours with second battery available as optional extra, excellent temperature distribution with air circulation system, low energy consumption through optimised insulation, digital temperature readout with accurate set point adjustment, separate control and display sensor, visual temperature alarm, dual magnetic seal, high-performance multi-LED interior light, lashing eyes on the sides of the unit, fast and secure fastening with lashing strap set supplied as standard, transport-proof closing system (can also be opened from inside), simultaneous cargo cooling and battery charging
Test marks	CE, TÜV/GS, E1, ATR, HACCP compliant, 74/408/EEC, crash tested according to ECE R80

Scope of delivery Set of cables, 1 large stainless steel grill tray, integrated gel battery, lashing strap set

Product	Ref. No.
CoolFreeze 850VAN	958.4020.20
Optional extras	
Stainless steel grill tray, large	991.1808.40
Stainless steel grill tray, small, top	991.1808.45
Extra battery set	991.1808.35
Universal 12-volt connection set	911.1808.50

NEW



At ambient temperatures of 16°C to 43°C:
Temperature range 0°C to +12°C



12/230 volts

Integrated gel battery

Up to 16 hours independent cooling with additional battery

LED interior light

1300 798 380
www.thermalmark.com.au

Compressor cooling container

NEW



Dimensions

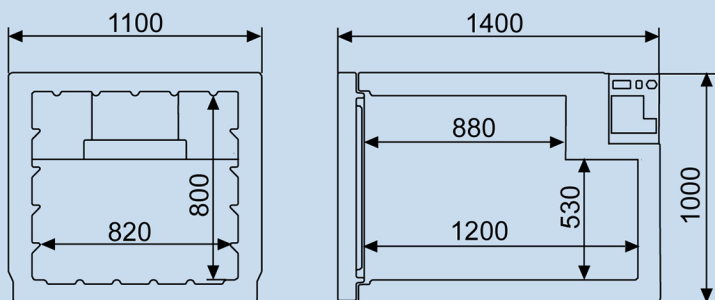

Fits the following types of vans with rear right-hand-side door; other vehicles on request.

Vehicle	Top width	Bottom width	Height	Depth
FORD Transit connect	1190	1220	1090	1460
FIAT Doblo	1160	1200	1180	1420
RENAULT Kangoo	1140	1220	1100	1450
CITROËN Berlingo	1120	1220	1100	1500
PEUGEOT Partner / Tepee	1400	1230	1070	1600

1300 798 380
www.thermalmark.com.au

