

# TM250 SERIES

## REFRIGERATION TRANSPORT SYSTEM

TM-250 Series by Thermal Mark is designed for fresh, frozen and deep frozen applications on medium sized trucks.

The compressor is driven by the truck engine. Integrated 240v electric standby model available upon request, (OED) Off Engine Drive supplied as standard.

### FEATURES & BENEFITS

- » **Optimum Performance**  
for superior cooling & less fuel consumption
- » **High Capacity & Airflow**  
to ensure even temperature distribution
- » **Exceptional Pull-Down**  
Capacity after regular door openings
- » **Low Operating Noise**  
allowing unrestricted deliveries in residential areas
- » **Intelligent & User Friendly**  
control system with digital in-cab display
- » **Electric Standby**  
240v
- » **Affordable Reliability**  
knowing your unit will have a long life cycle at a small cost

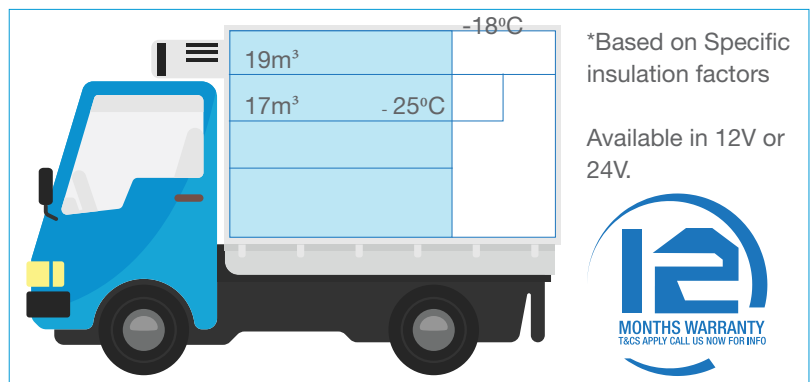

\*Based on Specific insulation factors

Available in 12V or 24V.



| Refrigerant Temperature |       | Road Operation TM-250II           | Electric Operation TM-250 ESC |
|-------------------------|-------|-----------------------------------|-------------------------------|
| °C                      |       | BTU/h                             | BTU/h                         |
| R-404a                  | 1.7   | 14,800                            | 11,000                        |
|                         | -17.8 | 8,000                             | 6,190                         |
|                         | -29   | 5,160                             | 4,160                         |
|                         |       | Condenser Dimensions (mm/ WxDxH)  |                               |
| Specifications          |       | Road Operation TM-250II           | Electric Operation TM-250 ESC |
|                         |       | 1153 x 430 x 372 - 32kg           | 1220 x 620 x 327 - 124kg      |
|                         |       | Evaporator Dimensions (mm/ WxDxH) |                               |
|                         |       | 860 x 585 x 328 - 29kg            |                               |