

TM100 SERIES

REFRIGERATION TRANSPORT SYSTEM

TM-100 Series by Thermal Mark is designed for fresh, frozen and deep frozen applications on small sized trucks.

The compressor is driven by the truck engine. Integrated 240v electric standby model available upon request, (OED) Off Engine Drive supplied as standard.

FEATURES & BENEFITS

- » **Optimum Performance**
for superior cooling & less fuel consumption
- » **High Capacity & Airflow**
to ensure even temperature distribution
- » **Exceptional Pull-Down**
Capacity after regular door openings
- » **Low Operating Noise**
allowing unrestricted deliveries in residential areas
- » **Intelligent & User Friendly**
control system with digital in-cab display
- » **Electric Standby**
240v
- » **Affordable Reliability**
knowing your unit will have a long life cycle at a small cost

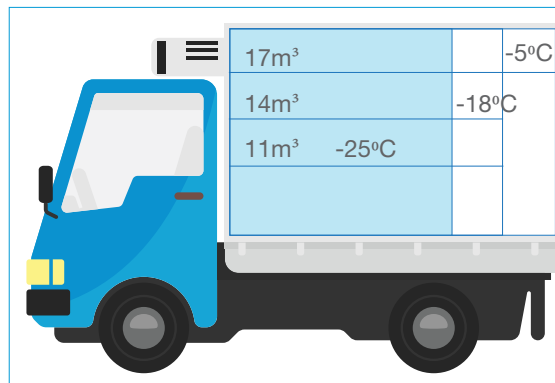
17m ³	-5°C
14m ³	-18°C
11m ³	-25°C

*Based on Specific insulation factors

Available in 12V or 24V.



12 MONTHS WARRANTY
T&CS APPLY CALL US NOW FOR INFO

Refrigerant Temperature		Road Operation TM-100II	Electric Operation TM-100 ESC
°C		BTU/h	BTU/h
R-404a	1.7	12,000	9,500
	-17.8	6,500	5,000
	-29	4,500	3,000
Condenser Dimensions (mm/ WxDxH)			
Specifications		Road Operation TM-100II	Electric Operation TM-100 ESC
		1115 x 464 x 267 - 25kg	1220.5 x 620 x 327 - 115kg
Slimline Evaporator 12 or 24 Volt Dimensions (mm/ WxDxH)			
991 x 620 x 168 - 24kg			